

Description

It is suitable for mixing common solder paste, paste, glue, slurry, and other material.

Features

- 1, Put the solder paste at 45 degrees, rotate along the axis direction, solder paste no longer adhere to the Cover.
- 2, With double safety devices to ensure personal security.
- 3, Remove air bubbles while stirring.
- 4, Using a dedicated control circuit, fully taking process control in consideration.
- 5, Proven speed ratio, avoiding too much solder powder and temperature rise impacts solder paste quality.
- 6, Don't need to remove cold storage of solder paste out of ice.
- 7, 500 g solder paste, mixing two cans at the same time.
- 8, Mixing process, no need to open the solder paste box.



Specifications

Machine Size(L*W*H)	440*440*550mm
Mixing capacity	500g/jar, 2jars/time
Mixing method	Centrifugal mixing
Mixing angle	45°
Power	1P AC110/220V 50/60HZ
Revolution speed	0~1200 RPM/min
Rotation speed	0~750 RPM/min
Machine Weight	35kg

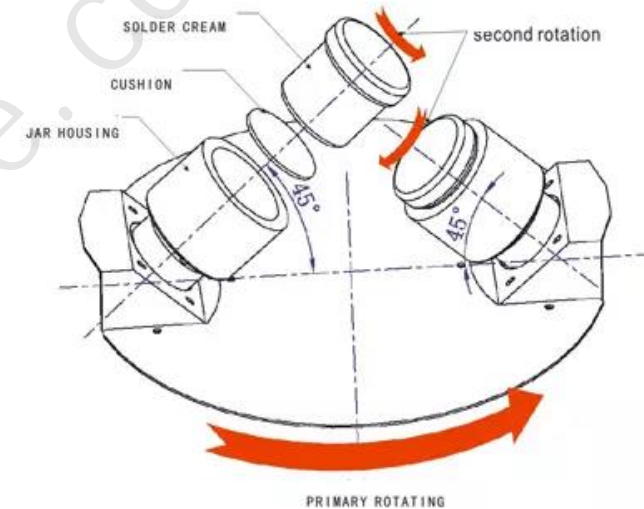



Welcome inquiry

1, Please visit : www.smtglobe.com

2, Welcome to our factory in China

7, Looking forward to your email: info@smtglobe.com

8. Wechat/Whatsapp/skype: +86 13825296910