

Description

SMT reject conveyor is used for faulty boards which can be lifted for visual inspection without interrupting the PCBs flow.

Features

Includes 3 modes: 'reject', 'inspect' and 'pass through'.
Stability enhanced by 'robust design.'
Ergonomically designed arm rest
Smooth and parallel width adjustment
Different lengths available upon request
Variable speed control
SMEMA compatible

Technical specifications

Transport height: 900mm \pm 20mm or specify.
Transfer direction: L to R or specify R to L
Belt type: ESD belt (round belt)
Speed: 0.5-20m/min adjustable
Power supply: AC 110 Volts Or 220 Volts;
Single Phase
Power consumption: 100VA max. or specify.
Buffering capacity: 5 PCB or specify.

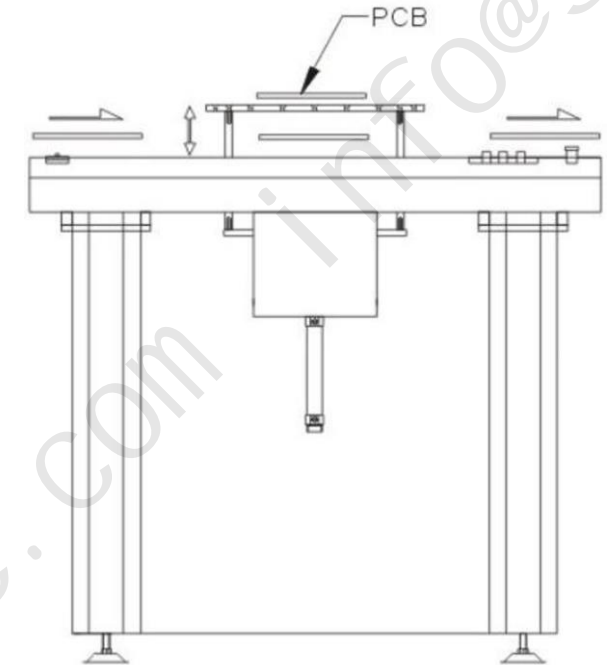

Model	Dimension (L*W*H.MM)	PCB size(MM)	Weight(KG)	Remark
EHC-355	500*665*900	50*50-445*350	50KG	no Lighting
EHC-467	500*795*900	50*50-460*460	70KG	no Lighting
EHC-358	1000*665*900	50*50-445*350	80KG	no Lighting
EHC-469	1000*795*900	50*50-460*460	90KG	no Lighting

Welcome inquiry

1, Please visit : www.smtglobe.com

2, Welcome to our factory in China

4, Google: SMT AGV robot; Magazine rack AGV robot; Manual PCB depaneling machine

7, Looking forward to your email: info@smtglobe.com

8. Wechat/Whatsapp/skype: +86 13825296910